

# Energy Efficient Door Control



---

**Karl Walestrand**  
**John Johansson**

Division of Industrial Electrical Engineering and Automation  
Faculty of Engineering, Lund University

# Energy Efficient Door Control



**LUNDS**  
**UNIVERSITET**  
Lunds Tekniska Högskola

LTH School of Engineering at Campus Helsingborg  
IEA

Bachelor thesis:  
Karl Walestrand  
John Johansson

© Copyright Karl Walestrand, John Johansson

LTH School of Engineering  
Lund University  
Box 882  
SE-251 08 Helsingborg  
Sweden

LTH Ingenjörshögskolan vid Campus Helsingborg  
Lunds universitet  
Box 882  
251 08 Helsingborg

Printed in Sweden  
Lunds universitet  
Lund 2017

## **Abstract**

This project is a broad study of ways to increase energy efficiency in an automatic sliding door. The study consists of several distinct phases. A research phase where traffic data was gathered, a modelling phase where the gathered data was used to create a traffic model, a test phase where a physical test door was set up and programmed according to the model, and finally an analysis phase where the gathered test data was analysed to identify how better energy efficiency might be attained.

Traffic data was gathered from observations of doors installed at retailers, hospitals, and train stations. This data was subjected to a statistical analysis in order to create a traffic model that was a composite of the observed doors. A java program was developed to create a traffic simulation based on this model. The traffic simulation would sequence the appropriate timing intervals for door openings and re-openings which was then programmed into an Arduino-card which controlled the physical test door

The physical test door was located in the ASSA Abloy test lab. During the tests this door was disconnected from the standard door power supply and was instead fed from the emergency battery packs that provide backup power to the system. The battery packs were connected in parallel with a lab power supply which delivered a small current. The energy consumption of the doors was measured with a logger which recorded the battery voltage and the current to and from the battery packs at regular intervals during the test sequence.

With the test equipment in place a series of power consumption tests were made. Initially several reference tests were made to establish a baseline for power consumption. Subsequent tests were then made to test various optimization methods in order to determine efficient ways to reduce power consumption.

The analysis of the results yielded several ways to improve energy efficiency that could be applied either alone or together.

Keywords: Sliding door, energy efficiency, Besam SL-500, door traffic, battery powered, energy optimization, DC engine, door sensors, sustainability, energy harvesting

## Sammanfattning

Detta arbete tar sin grund i en övergripande studie i energioptimering av en automatisk skjutdörr. Studien omfattade flera distinkta faser. En första undersökningsfas som samlade in trafikdata, en modellfas där en trafiksimulering skapades utifrån insamlad data, en testfas där en testdörr sattes upp och styrdes enligt simuleringsmodellen, och slutligen en analysfas där all insamlad testdata analyserades för att identifiera möjligheter för energioptimering.

Trafikdata samlades in genom observation av dörrar till butiker, sjukhus, och tågstationer. En statistisk analys gjordes på den insamlade datamängden för att skapa en trafikmodell som var en kombination av de observerade dörrarna. Ett enkelt javaprogram utvecklades för att skapa simulerad trafik utifrån trafikmodellen. Trafiksimuleringen gav en sekvens av tidsintervall för öppningar och återöppningar som sedan programmerades in som körprogram på ett Arduino-kort som styrde testdörren.

Den fysiska testdörren var placerad i ASSA Abloys testlab. Under test så var denna dörr inte inkopplad på nätström. Dörrens motor matades istället med batteriström från dörrens nödbatterier parallellt med en liten ström från ett labbaggregat. Energiförbrukningen mättes med en logger som loggade batterispänning och batteriström vid regelbundna intervall under testet.

Med testutrustningen på plats så gjordes en serie av tester av energiförbrukningen. Ett antal referenstester gjordes först för att kunna se en basnivå för energiförbrukningen. Efterföljande tester gjordes sedan för att testa olika optimeringsmetoder för att ta reda på vilka metoder som effektivt kan minska energiförbrukningen.

En analys av testresultaten visade på flera olika sätt att förbättra energioptimeringen som kunde tillämpas enskilt eller tillsammans.

Nyckelord: Skjutdörr, energieffektiv, Besam SL-500, dörrtrafik, batteridrift, energioptimering, DC-motor, dörrsensorer, hållbarhet.

## **Foreword**

We didn't realise it at the start but this project he had in mind was very broad in scope and the challenges it presented were not all straightforward. We ended up studying door traffic, created traffic models, designed a test program, built a test rig, analysed test data, and through it all we had to come up with our own solutions and test our instincts as well as our skills. It was a great experience and a fantastic education in what we could do when given a real task to test ourselves against.

We would like to give a big thanks to Roger Dreyer for giving us this opportunity and guiding us along. We also want to thank Mats, Johnny, Gunnar, Dennis, and everyone else at ASSA Abloy in Landskrona for their kind support. Thanks to Henriette Weibull and Mats Lilja at LTH. A special thanks to Andreas who helped make it possible.

# Table of Contents

1 Introduction .....	1
1.1 Background .....	1
1.2 The company.....	1
1.3 Purpose and objective .....	2
1.4 Problem definition.....	2
1.5 Limitations .....	3
1.6 Sources .....	4
2 Technical background .....	5
2.1 Observation tools.....	5
2.2 Software .....	5
2.3 Components & Instrumentation .....	7
3 Methodology.....	9
3.1 Field study .....	10
3.1.1 Terminology .....	11
3.1.2 Field data analysis .....	12
3.1.3 Profiles.....	12
3.1.4 General characteristics .....	13
3.2 Modelling and simulation .....	13
3.2.1 Java Simulation .....	15
3.2.2 Setup .....	18
3.3 Test setup.....	21
3.3.1 Measurements .....	22
3.3.2 Data analysis .....	24
3.3.3 Notations and Formulas .....	24
3.4 Testing.....	26
3.4.1 Reference testing.....	26
3.4.2 Regeneration testing.....	27
3.4.3 Optimization testing .....	29
4 Results and Analysis .....	33
4.1 Results .....	33

4.2 Sensors .....	33
4.3 System settings .....	35
4.4 Regeneration of energy .....	35
4.5 Different wheels.....	38
4.6 Battery-assisted power supply.....	39
5 Conclusions .....	41
5.1 How was door traffic measured? .....	41
5.2 How can door traffic be modelled? .....	42
5.3 How can the door be Optimized for lower energy consumption?.....	43
6 Future Development.....	45
7 References.....	47
Appendix A .....	49





# **1 Introduction**

ASSA Abloy Entrance Systems presented an opportunity to work on a project that would help improve their existing products as well as provide knowledge that could be applied to the design and production of future products by increasing the energy efficiency of automated doors.

## **1.1 Background**

ASSA Abloy Entrance Systems is looking for ways to lower energy consumption in their line of automatic doors. This can be achieved in a variety of ways but the thesis project intended to focus on the door motor initially by testing if the motor could act as a generator when the door is braking without externally modifying the existing hardware. If power could be generated during these tests then the motor could be further optimized to maximise the regenerated power. This would then help the company to lower energy consumption on its automatic doors and would help the company to bring sustainable solutions to the marketplace.

This project will work with the Besam SL500. The Besam SL500 is an automatic sliding door operator. It is surface-mounted to the wall or to a beam and it can be adapted to a wide range of door requirements for internal and external sliding doors.

## **1.2 The company**

ASSA Abloy Entrance Systems (AAES) is a division of ASSA Abloy. AAES makes a wide range of automatic entrance products and solutions for a global market and has over 9,000 employees worldwide. These products are found in grocery stores, warehouses, airports, and anywhere else an automatic door solution is needed. Landskrona, Sweden, is where the company does research and development on its sliding doors, revolving doors, swing doors, as well as cargo ports. There is an extensive test lab facility situated next to the R&D department. The company has a focus on sustainability in production

and design and wanted to offer a thesis project that could help them achieve that goal.

### **1.3 Purpose and objective**

The purpose of the thesis project is to lower the energy consumption on the Besam SL-500 sliding door operator manufactured by AAES. The hypothesis driving this project is that it is possible to take advantage of DC motor characteristics to harvest the energy from braking the door in a way that will regenerate more energy than the current circuit is capable of, and in that way lowering total energy consumption. Any adverse effects on the performance of the door will be noted but they are tangential to the goals of the project.

### **1.4 Problem definition**

Can energy consumption in a Besam SL-500 automatic door be reduced? This is the focus of this project and the question it seeks to answer.

This breaks down into several smaller questions.

- How will door traffic be measured?
- How can door traffic be modelled and what will that model represent?
- How can the door be optimized for lower energy consumption?

In order to make proper tests there is a significant amount of preparatory work to be done first to answer those questions. How will energy consumption be measured and what tests need to be run? The project will need to identify specific optimizations that can be made to improve sustainability. In order to run the tests under realistic conditions a test model that mirrors real-world traffic will need to be developed.

## 1.5 Limitations

In the field study phase the data was taken from a three observation sessions per door in each location. The time of day or the day of the week affects traffic patterns and the measured traffic at these three specific times may not be a good representation of the average traffic through that door. The number of observation sessions was limited by the allotted time for observations. Observed traffic data is a snap reference for a specific interval and was not representative of the average traffic through any given door.

The door leaf weight was approximated by assuming the door is a plain glass sheet with a thickness of 8mm. The difference in weight between the glass and the door frame is assumed to be negligible.

The project will only look at electrical energy consumption in the Motor Controller Unit (MCU) and connected components like the sensors and the Operation Mode Selector (OMS). It will not take into consideration how an automatic door affects the heating or cooling of the building it is installed in.

The door was powered by battery packs during the tests and this limited the maximum current available for the DC motor which will reduce maximum motor torque compared to the standard power supply.

The rapid charge and discharge cycles of the battery packs using the test setup reduced the battery lifespan. This was not factored into the tests as test sessions were short and infrequent and underperforming battery packs were simply replaced.

The study focused on optimising the existing system by modifying or adding components.

Timing data for openings was calculated using a stochastic model based on real-world frequency distribution but timing data for re-openings could not be accurately sampled so the model had to fall back onto a uniformly distributed randomization there.

## 1.6 Sources

The textbook “*Diskret matematik och diskreta modeller*” [1] was used as a reference for the statistical modelling phase of the project.

MATLAB technical documentation [2] was used as a reference while analysing the test data using MATLAB software.

The Installation and Service Manual for Besam SL500SL [3] was consulted while setting up the test rig.

“*Power Electronics, Devices, Converters, Control and Applications*”[4] gives an overview of the DC-DC boost converter

“*Power Electronics, Devices, Converters, Control and Applications*” [5] also covers the 4-quadrant DC chopper

“*Electric Power Systems*” [6] for an overview of generators.

Arduino Uno technical specifications [7]

Arduino Uno software reference [8]

“Four Quadrant Operations of DC Motor” [9] for an overview of regenerative braking.

A search through existing literature and article databases using the keywords “automatic”, “door”, “energy”, “sustainability, and “energy reuse”, “sliding door”, “harvesting”, alone or in combination, did not yield any results that could be used or referenced during the project.

## **2 Technical background**

This chapter covers a detailed description of the tools and resources used during the course of this project.

### **2.1 Observation tools**

The following tools were used during the observation phase.

- Mechanical counter
- Stopwatch
- Mobile camera set to capture at 60 FPS

A hand-held mechanical counter was used to count people during the observation sessions. The counts were written down using pen and paper. Measuring the total time the door was open during an observation session was not strictly needed for the modelling but it did provide a useful reference point to check the model against. A stopwatch was used for this purpose. In order to measure the opening speed or the closing speed of a door a stopwatch was not accurate enough. A high-resolution camera filming at a 60 frames per second made the process simple as the door motion can be tracked between frames with exact time stamps. If the door width is known then the speed can be calculated from that.

### **2.2 Software**

The following software was used during the course of the project

- Microsoft Excel 2013
- IBM SPSS Statistics 23
- Eclipse Java Mars
- Arduino 1.6
- Matlab

The observation and test phases both generated a lot of data that needed to be analysed. For the observation phase Microsoft Excel was sufficient to manage this data, both serving as a data entry form as well as providing simple graphs and making calculations when necessary.

During the test phase the number of data points grew to such an extent that handling the data in Excel proved to be unwieldy. Excel was fine with a couple of hundred data points but test runs commonly generated tens of thousands of data points. For this reason and in order to have access to more powerful tools Matlab software was used for all test data analysis.

Matlab is a widely used program for technical and mathematical calculations that comes with its own scripting language. In this project Matlab was used to make numerical calculations on data sets with up to hundreds of thousands of data points and graph the results for analysis.

In the modelling phase the simulation was programmed in Java using the Eclipse IDE. In addition to the data taken from Excel a frequency distribution was needed for the model and since there was no easy way for Excel to do that IBM SPSS statistics 23 was used as a complement.

IBM SPSS Statistics is a widely used program for statistical analysis in the social sciences. The program has a wealth of features and can be used in a wide range of fields but its use in this project was limited to generating frequency tables from Excel tables.

The Arduino Uno card that was used to control the test door was programmed with the Arduino 1.6 software. The Arduino programming language is a simplified version of the C programming language. [8]

## 2.3 Components & Instrumentation

The following components and hardware were used during the thesis work

- Delta Elektronika SM 70-22 (Ps.70-22)
- Deltaco 2.1 A USB charger (USB wall plug)
- Power Box 3601ds (PB.3601ds)
- DC-DC boost converter Module XL6009 (DC-DC converter)
- Arduino Uno rev. 3 (Arduino board)
- Keysight 34972A data logger (DAU unit)
- Agilent DSO6104A oscilloscope
- Besam SL-500 sliding door
- Micro switch (“Closed sensor”)
- Piston switch (Fully open sensor)
- Mean Well GSM25E12-P1J 12VDC/2.08A (Wall adapter)
- Mechanical counter
- Stopwatch
- Mobile camera with capability of filming at 60 fps
- 1 Ohm resistor (R1)
- 0.02 Ohm resistor (R2)

A Keysight 34972A Data Acquisition Unit (DAU) was used for measurements and logging during the tests. The instrument measured voltage over resistor R1, resistor R2, and over the battery poles with 100ms intervals and logged the data in a CSV file. (See figure [3-2] for circuit schematic)

A Ps.70-22 power supply was used to supply current in parallel with the batteries. Output voltage was set to 29V and current was limited to 0.9A for profiles P1, P2, P3 and for P4 current was limited to 1.2A. For more information about the test profiles see chapter 3.2.3. A 25W wall adapter was used to investigate its potential as a power supply during the later stages of optimization testing.

By using a DC-DC boost converter [4] connected after the power supply the voltage could be adjusted to match the batteries when driven from power supplies with a lower constant voltage.

The power box 3601ds was used for powering the Arduino board.



A digital storage oscilloscope was used to calibrate PS output voltages prior to testing.

The Arduino Uno board based on ATmega328P microprocessor was chosen since it is cheap, easy to use, has a good range of input/output connections, and is easy to program for simple control tasks such as opening a door on a fixed schedule. The microcontroller is already mounted on a circuit board with all the necessary components which means it is ready for use straight out of the box. [7]

### 3 Methodology

The majority of the work on this project can be separated into three distinct phases.

An initial **field study phase** was needed to gather traffic data. This involved figuring out what data the project needed to gather, figuring out how to gather it effectively, and finally sitting down and taking observations in the field to personally gather the data needed for the project.

Next came a **modelling phase** where the traffic data was analysed for traffic patterns. The patterns were used to create a software model of foot traffic through a simulated door. After the model was developed a representative opening sequence was then captured for use in programming the physical test door.

Finally there was the **testing phase**. A test door was set up in a lab environment with measuring equipment connected. The opening sequence that was captured from the test model was programmed onto a control board to run the door through a test cycle and test data was gathered and analysed to determine the potential for energy optimization.

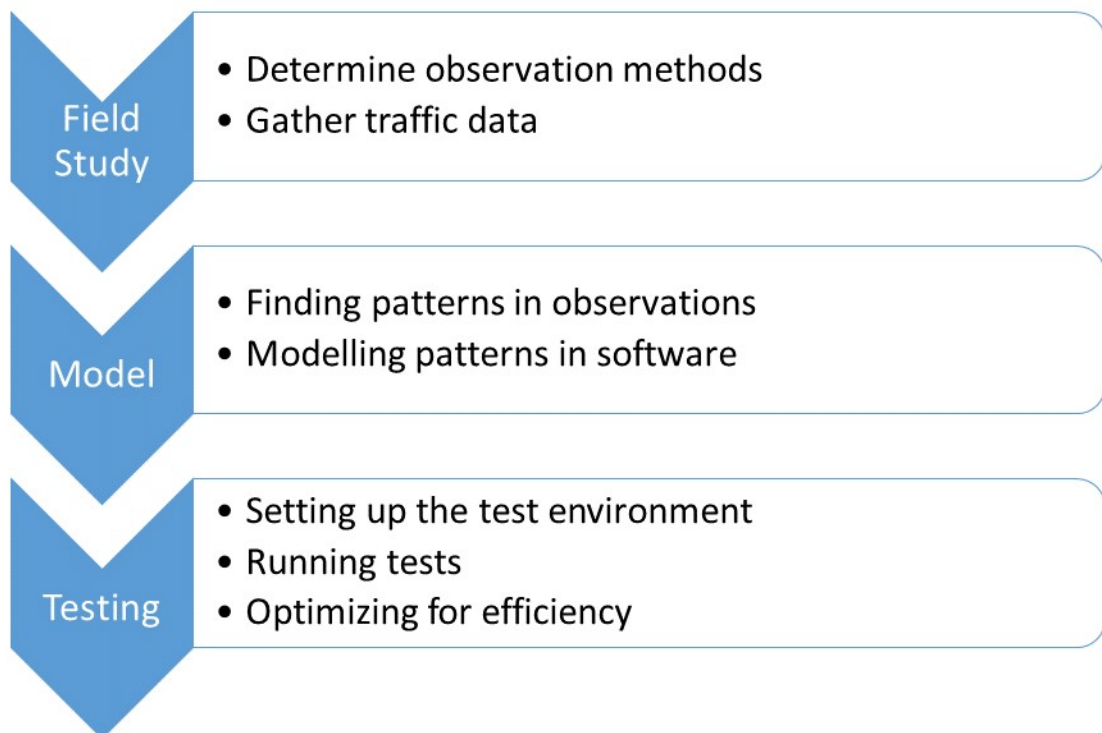

### 3.1 Field study

The field study was conducted over the span of 10 days. During this time the aim was to examine a variety of locations to get a good sense for what kind of traffic a sliding door would see in real world locations. The doors included in the study were chosen from retail, transportation, and healthcare sectors to try to get a broad sample. A total of seven locations were chosen for the study. See table [3-1]

<b>Door installed at:</b>	<b>Location:</b>	<b>Category:</b>
ICA Malmborgs	Clemenstorget, Lund	Grocery store
Coop Nära	Trollebergsvägen, Lund	Grocery store
IKEA	Väla, Helsingborg	Large retailer
Burger King	Knut Den Stores gata, Lund	Fast food restaurant
Knutpunkten	Helsingborg	Transportation hub
Malmö Central station	Malmö	Transportation hub
Lund University Hospital	Lund	Hospital

[Table 3-1]

At each location one pair of doors was chosen for observation and a total of three observation sessions were conducted. The observations were limited to having only two observers available to record data during the sessions and most data was recorded through visual observation alone. The data categories are described below and were as follows:

### 3.1.1 Terminology

**Openings:** A door is considered to be in either of two states, open or closed. When a door is fully closed and motionless and then starts to move that counts as one opening. When a closing door stops moving it is closed. When a door goes from being closed to being open and then back to being closed it is said to have completed one cycle.

**Re-openings:** A re-opening is when a closing door halts and opens again when the door sensors detect approaching traffic. A re-opening is counted if the door state is open, it is closing, and it halts and opens again.

**Passages:** Every time a person goes through the door from one side to the other that counts as one passage. In case the same person immediately goes back out through the door then that is another passage and is counted separately. The direction of passage is not taken into account.

**Door cycle time:** A door cycle is when the door goes from a closed state to an open state and back to a closed state again. The door cycle time is the time that it takes for a door to complete a cycle with no more than one impulse from the sensor. This is the shortest possible cycle time since no re-openings take place during it. The cycle time was measured with a camera filming at 60 frames per second. This allowed the measurement of opening, holding and closing times, all by going through the footage frame by frame and noting the time stamps.

**Group size:** A group is a cluster of passages that has occurred during one cycle of the door. The group size is the amount of passages during that cycle.

**Opening time:** The time it takes the door to go from closed to fully open.

**Hold time:** The time the door stays fully open.

**Closing time:** The time it takes the door to go from fully open to closed, without any re-openings taking place in the interval.

**Door opening width:** Measured with a tape measure from the inner edge of one open door leaf to the other. Rounding was made to the nearest dm.

**Door leaf width** and **door leaf height**: were measured with a tape measure to the nearest dm.

**Door weight**: Approximated by taking the door area and calculating the mass as if the door was a solid sheet of 8mm thick glass.

**Total time in use**: The amount of time the door is in use, measured as any time when the door is not closed.

### 3.1.2 Field data analysis

The collected data from the case study was input into a Microsoft Excel workbook. The observation sessions were not all equal in length so where applicable all data was normalized to represent one-hour long sessions by calculating a scale factor from the session time in minutes divided by 60 minutes. This scale factor was then applied to all measured data during that session.

Excel was used to graph the data for easy visualisation and analysis. These graphs showed that doors with a similar amount of traffic/hour had a similar quota of openings/re-openings. Openings and re-openings are the most significant events from the perspective of energy efficiency as it is there that additional energy is expended on acceleration and deceleration of the door. The opening/re-opening quota similarity meant that doors could be grouped according to traffic and observations of different doors with similar traffic patterns could all be assigned to one single traffic profile. The seven doors were grouped into three profiles and the average value of the data sets was calculated for all doors observed.

### 3.1.3 Profiles

A profile is an aggregation of observation data. The purpose is to be able to take a number of observation sessions and extrapolate the average values of those sessions into a single data set. Ideally this will average out differences and result in a representative version of the doors that are used to make up the profile. A profile can be made from a single door as is the case with profile 2, in which case the profile will simply smooth out differences between observation sessions but still

represent that one real door, or it can be made from several doors, in which case it will represent a virtual door that has the average characteristics of the doors used to make the profile as is the case with profiles 1 and 3. In order to get a usable profile from data taken from several different doors it is important that the doors share similar traffic characteristics, an overview of which can be seen in table [3-2]. For test purposes the most important characteristics are the opening/re-opening ratio as well as the total number of passages.

### 3.1.4 General characteristics

The three traffic profiles have the following characteristics.

<b><u>Profile 1</u></b>	<b><u>Profile 2</u></b>	<b><u>Profile 3</u></b>
Low traffic	Low-Medium traffic	High volume of traffic
Light door leafs	Heavy door leafs	Medium weight door leafs
Few re-openings	Regular openings and closings	Almost constant re-openings
Slower door speed	Widest opening width	Fastest cycle time

[Table 3-2]

## 3.2 Modelling and simulation

Making profiles was only a first step. In order to use them for testing the timings of openings and re-openings needed to be extrapolated from the profiles. The profile had the average values for opening intervals and re-opening intervals but the goal for the test program was to recreate a realistic traffic pattern. That meant the doors could not be programmed to open at averaged intervals as real traffic does not

follow regular patterns. To solve this problem a stochastic model was used and a simulation was built that would take profile data as inputs and output a traffic pattern that was representative of the target profile using stochastic modelling for probabilities.

The profile group size data was input into IBM SPSS Statistics to calculate group size distribution and it would then output distribution frequency tables. The frequency tables could then be used to make a model for group sizes. This has the advantage of being able to add a large number of data sets into a single composite model which makes for a more even distribution of probabilities. In this way the model solves the problem that would arise if we were to pick among the many data sets to use one of them for testing as it is hard to determine the most representative sample. A stochastic model allows for the creation of an entirely new simulated data set that shares the same probabilistic distribution as the recorded data sets. Because it has the same probabilistic distribution it is a realistic representation of actual door behaviour and it is this simulated data set that was used to test the doors.

The collected data was limited in one aspect. It could not account for individual passages inside a group. This was not apparent at the time of the field studies but it did have some implications for the simulation. Given the data it is possible to tell the probability of a group arriving at any given point in time as that will trigger an opening and the intervals between openings were recorded. However it is not possible to determine the probability of an individual passage that occurs within that group since the intervals between passages were not recorded. If a group contains 10 passages the collected data will not give any information about specific passages during that interval of time. It could be evenly distributed, it could be weighted, or it could be scattered randomly, with no way to tell.

### 3.2.1 Java Simulation

The stochastic model was used as the basis for a java simulation program. The program used the model data as inputs into a simulation of one hour of traffic according to the selected profile. The program was set to loop through a counter with each step representing one second of elapsed time. At every step the program checked against the probability of an opening event occurring. The probability was a simple calculation of profile openings/second averaged over an hour. If no opening takes place the counter is increased by one and another check is made. If an opening event does take place the program would determine the group size using the frequency table distribution of group sizes. With the group size determined it would then calculate the number of re-openings to take place during the opening event by multiplying the probability of re-openings with the group size. Finally the counter would be increased by a number of steps depending on group size to account for the time the door is open. The program would run until the counter reached 3600, marking an hour of simulated time.



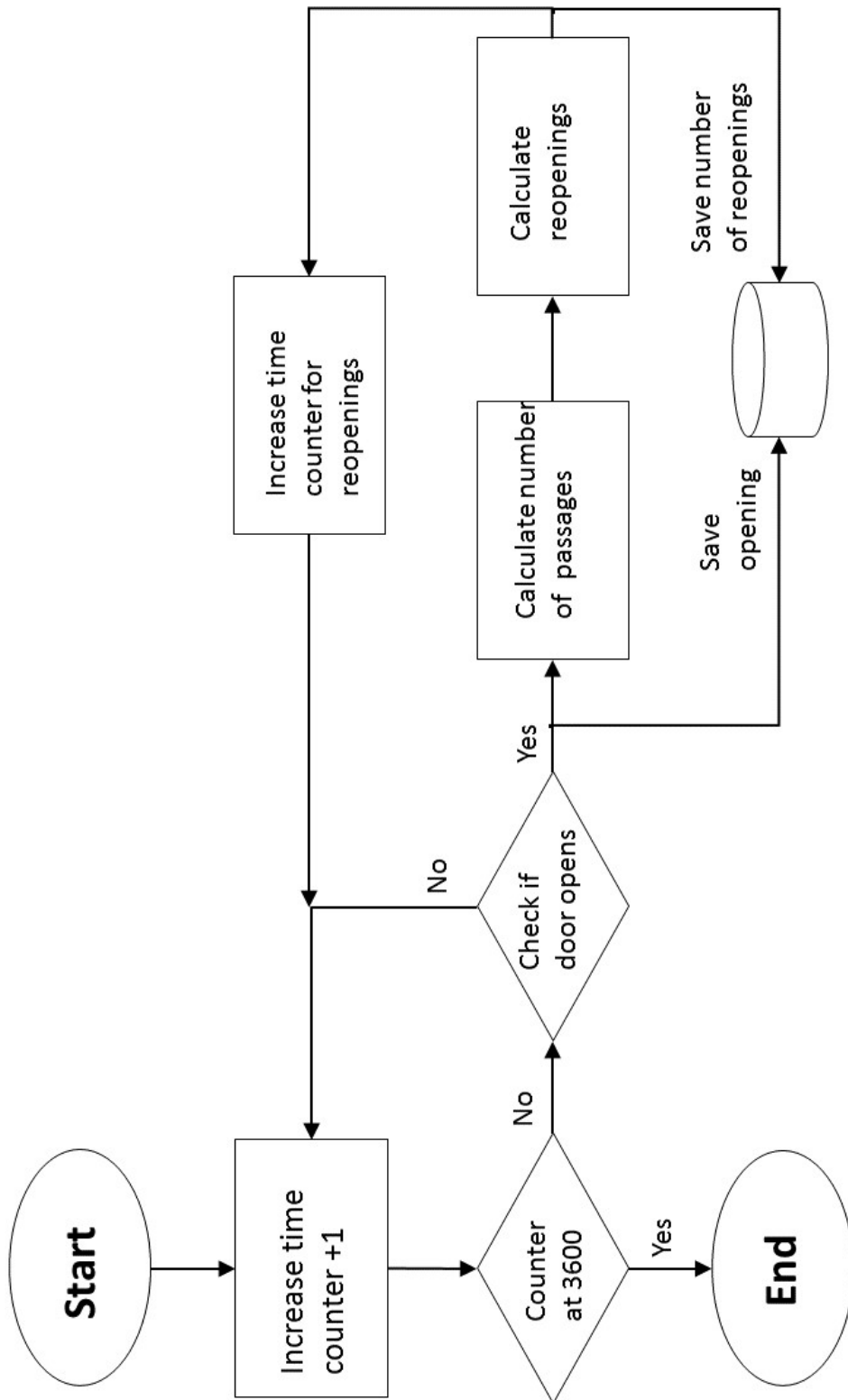

[Figure 3-1] Simulation logic

At every opening event the program would save the opening interval along with the number of re-openings in the opening event. The program would also record additional variables such as the number of passages, openings, re-openings, groups, and the maximum group size that had been simulated in order to allow for easy comparison with the real-world data.

For an overview of the basic logic see figure [3-1].

In order to fine tune the simulation hundreds of thousands of simulations were run with the outputs added together and averaged before a comparison to real-world data was made. Where there were differences between the simulation and the real-world data the simulation inputs were changed to give outputs that were closer to the recorded data sets. This was done for six to eight iterations for each profile until the simulation returned averages that matched the recorded data sets with an error margin of 1-2%. Once the simulation was confirmed to be a close match to the recorded data sets a final simulation run was done to generate a traffic program for the profiles, P1, P2, and P3.

A fourth profile, P4, was created by looping P1 ten times as there was a need for a profile for endurance testing to simulate a full day's worth of traffic. The test data could not provide an accurate account of traffic patterns over an entire day as that would require far more extensive field observations that could not fit into the allocated time schedule. Looping P1 would not account for peaks and troughs in traffic but it would serve as a functional endurance test.

The simulation is limited in some aspects. It only models groups, not individuals. Anything that happens between an opening and a closing takes place in a black box. The model depends on keeping the door opening time, door hold-open time, and door closing time in the test rig the same as in the simulated model. If the model assumes that an opening takes two seconds but the physical test rig is set to three seconds that will make the model less accurate. To see why, assume there is a real door with a certain traffic pattern that in turn leads to a certain amount of openings and re-openings. If the closing speed is set to be a little slower, there will be fewer openings as more people will have time to pass through the door before it can close. On the other hand there will be more re-openings as there will be a longer interval when the door is in motion and can be interrupted during

closings. And conversely a faster closing speed would lead to more openings and fewer re-openings. The further a change deviates from the assumed values the more uncertainty it introduces into the simulation as the model cannot tell where the extra re-openings will take place or with what frequency.

Despite these limitations a decision was made to only run the simulation once to account for the initial conditions. No matter what improvements or changes are made to the door afterwards it will always follow the same profile without changing the timing intervals between openings or the number of re-openings.

### 3.2.2 Setup

When setting up the test door it was important that the physical characteristics of the door would closely resemble the characteristics of the simulated profile doors. All profile doors were assigned a weight and a door opening width based on the observation data. P1 tests, P2 tests, and P3 tests all had different widths and door weights and these had to be changed between test runs of different profiles.

The profiles were also assigned different MCB user settings to account for different door speeds, hold-open times and more or less aggressive acceleration. The MCB is the Main Control Board for the door. The MCB user settings for a Besam SL-500 have 90 different variables and since several of these variables have to be changed for each test profile each set of variables that was paired with a profile was given a letter designation from A to G to make it easy to refer to. A list of MCB settings can be found in Appendix A.

The Arduino Uno board was used to run the traffic simulation. The simulation relies on feedback from two switches that serves as door positioning sensors. All references to switches and sensors can be seen in the circuit schematic in figure [3-2] while a basic overview of the setup is shown in figure [3-3]

The first switch (Closed.Sense) is positioned on the door frame and closes its circuit when the door is closed. The second switch (FullyOpen.Sense) is positioned on the door rail so that it will close its circuit when the door is fully open. The fully open sensor makes sure that the Arduino board always knows in which state the door is in. This

makes sure that the board only sends impulses to the door when the door is in the correct state and prevents timing issues from creeping into the tests.

The code for the Arduino is written so that it produces an abort every tenth of a second. The simulation is only updated once every second but the faster abort cycle gives better accuracy from the sensor inputs.

The run cycle is determined from two vectors, one for the opening times which is scaled in 100 millisecond steps and one for the number of re-openings that cycle. The 100 millisecond steps and not 0.1 steps is done to optimize performance and memory usage from the Arduino board by using integers. The element position in the vector indicates the cycle number.

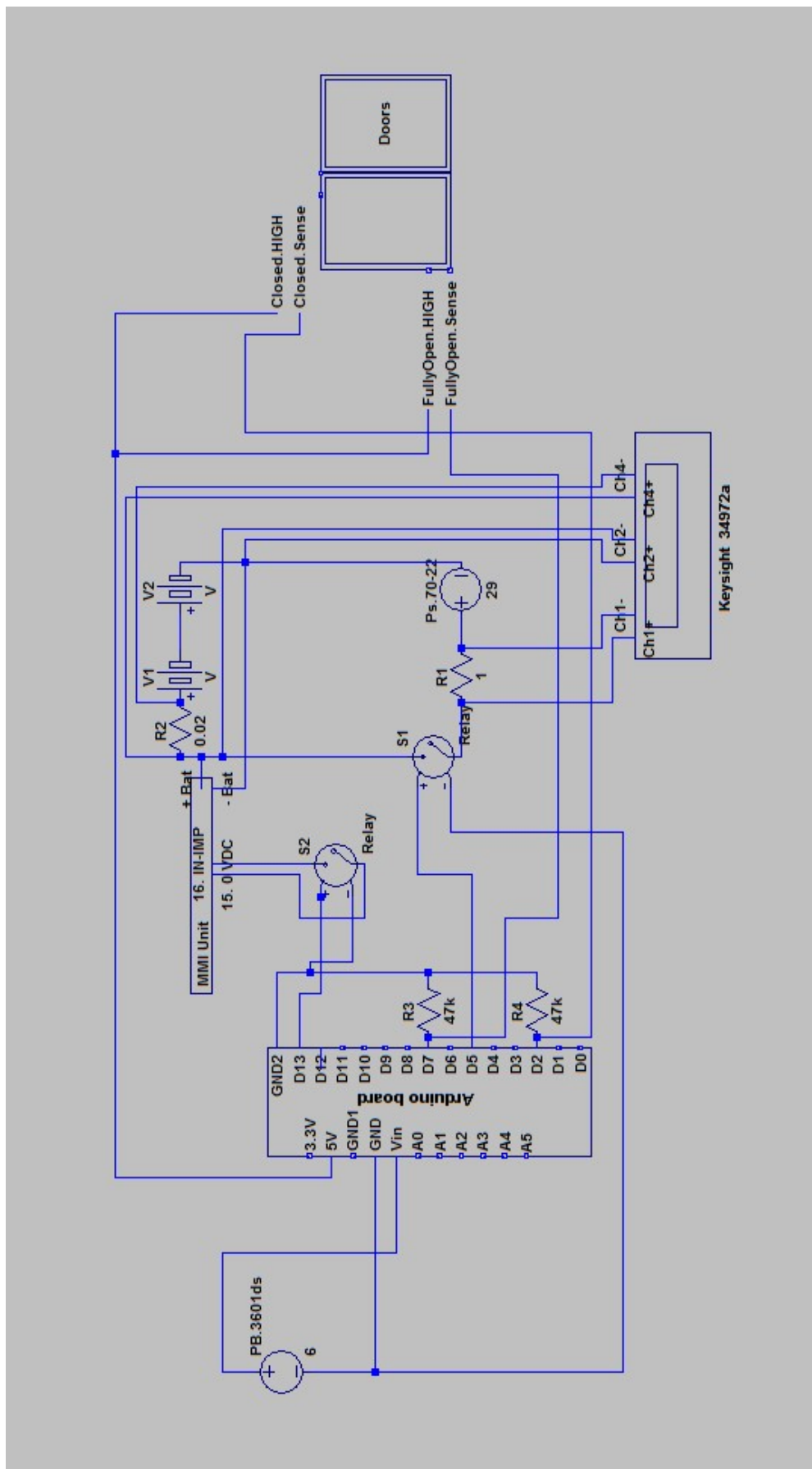

[Figure 3-2] Circuit schematic

### 3.3 Test setup

To test the power consumption ASSA Abloy provided a door testing rig comprised of a SL-500 motor, a power converter, a control system, and door rails with door leaves. The door leaves were hollow metal frames mounted on the rails and the frames could be loaded with metal bars to increase the door weight as desired. Two switches were installed. One switch was mounted on the door leaf to detect if the doors were closed, the other switch was positioned on the test rig to detect if the door was fully open. Both sensors were then connected to the Arduino board. The Arduino board used the input from the switches as part of the control program to determine when to signal an opening to the MCB. Power was supplied from the powerbox in parallel with batteries which connected to the MCB using the battery port. The logger measured the current of both the batteries and the powerbox for later analysis. The MCB in turn controlled the motor which powered the door leaves. An overview is provided in figure [3-3].

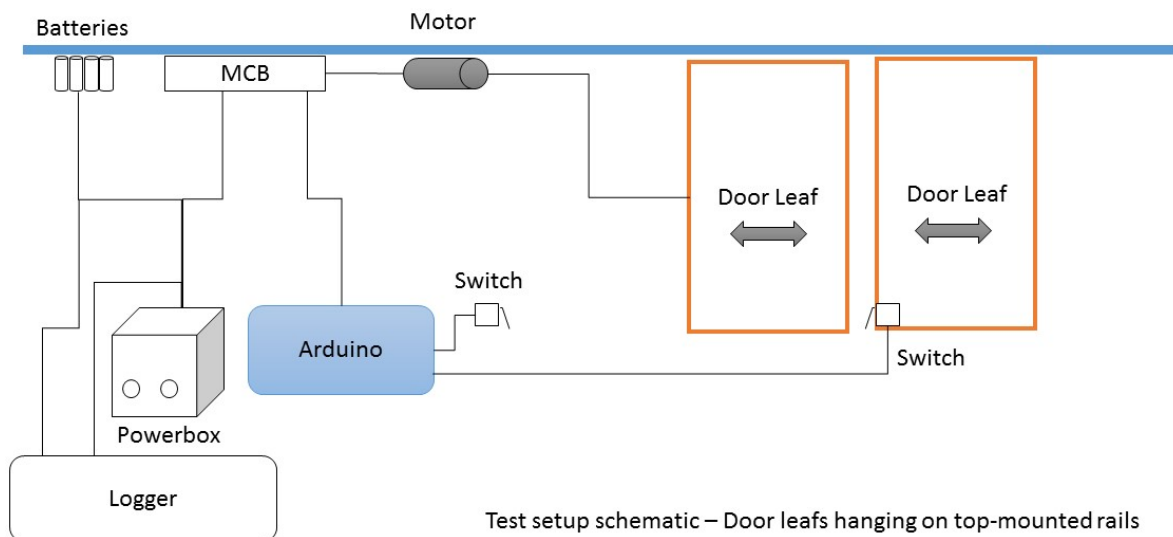

[Figure 3-3] Test setup

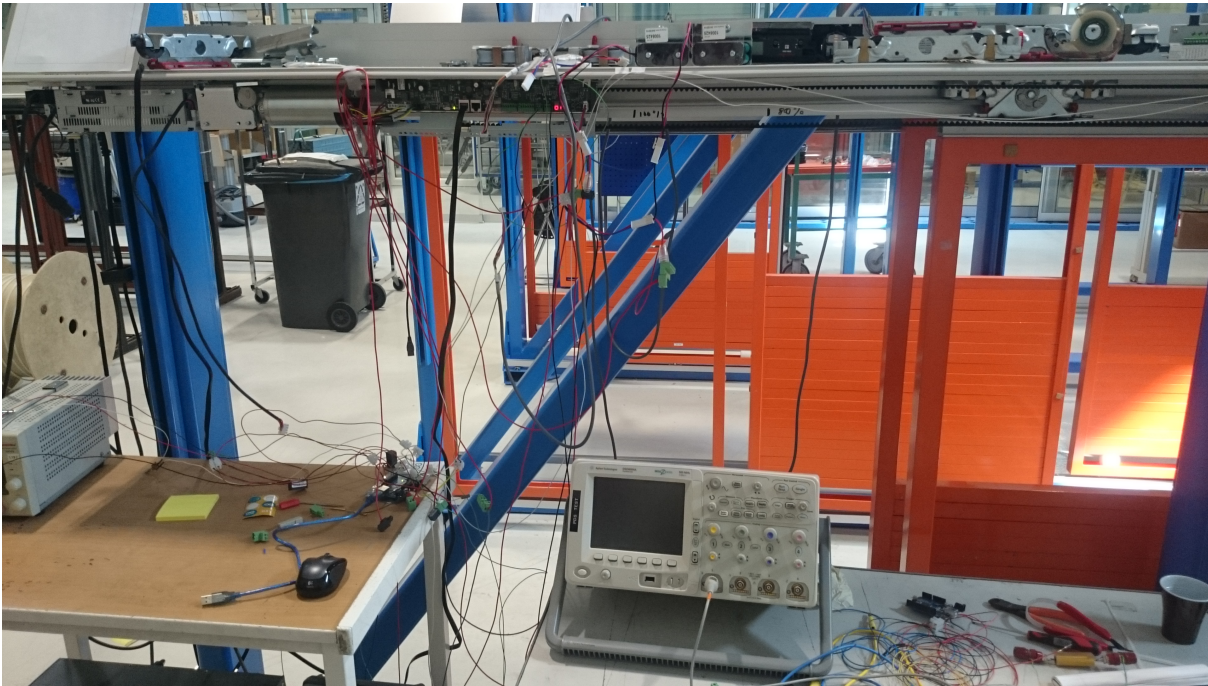

[Figure 3-4] Image of the test rig during testing

Figure [3-4] shows the motor and the MCB mounted along the top rail to the left with the hollow door leaf to the right. Battery packs are placed on top of the rail. The powerbox and logger are both out of frame on the left. In the center of the image is the digital oscilloscope.

### 3.3.1 Measurements

The logged data from the DAU is truncated to only include data points during the test since the DAU has to be started and stopped manually and this adds additional time before and after the test profile. To get a reference point for the data measurements additional “dummy” door openings are added to the start of the profile with a known interval. A test profile can start with several seconds where there is no traffic and there is no way to tell where the test starts during that time without a dummy opening at the beginning. Since the data recording and the Arduino both have to be started manually these additional openings act as a signal that can be seen when analysing the data graphs. The dummy openings show where to truncate the recordings to cut off junk data.

The data recorded before the last current spike in the dummy openings is discarded. For all profiles except P4 there are two dummy openings. For P4 it is one dummy opening due to minor programming limitations that needed to be worked around given P4:s extended run time. Two openings were chosen to give maximum visibility on the test graphs but one dummy opening is sufficient for these purposes. Figure [3-5] shows an example of what this looks like. The logger is turned on and starts recording before the Arduino begins the test sequence which can be seen at the left edge of the graph. The two dummy openings can be seen inside the small box. The circle marks where the data is truncated right after the last current spike.

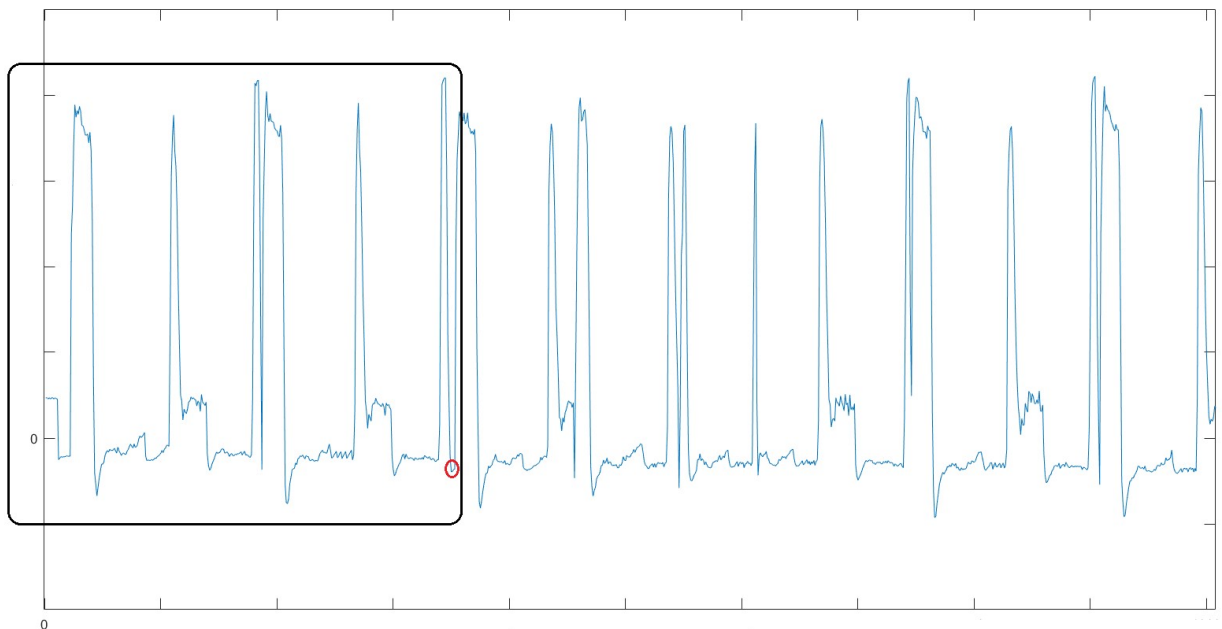

[Figure 3-5] Dummy openings

A test run takes 50-60 minutes to complete on average. The end point is set after the last current spike of the profile and all data recorded after that point is also discarded. Because of the manual start and the need to truncate the data the start and end points can differ +/-5 measurement points or around 500ms between test runs. This truncated data is then used as the basis for all calculations.

The voltage over resistors R1 and R2 is taken and used to calculate the current through the resistors. The current through resistor R1 is the current supplied by the PS to the system. The current through resistor R2 is the current to and from the batteries.



There were some problems with the door switches that made the Arduino board misread the signals. The fault turned out to be noise and approximately a 50 Hz sine wave caused by lack of a pull up/down or too big pull up/down resistor that didn't ground the input properly and made it float. The solution was to fit 47 k $\Omega$  resistors across the input used to ground.

### 3.3.2 Data analysis

The data was recorded in a CSV file and stored on a USB memory due to lack of internal storage in the DAU unit. The data was then transferred to a computer where it would be analysed in Matlab. The measured voltage over the 0.02  $\Omega$  resistor R2 was multiplied by 50 to get the battery current  $I_B$ . The battery current was multiplied with the measured battery voltage to get the battery effect  $P_{BAT\_MCU}$ .  $U_B$  is the voltage measured just after the resistor R2.

The current from the power supply was measured with a 1  $\Omega$  power resistor R1 which meant it could be translated directly into current as  $I_{PS\_BAT}$ . The power supply current  $I_{PS\_BAT}$  was also multiplied with the measured voltage  $U_B$  to get the effect  $P_{PS\_BAT}$  from the power supply. To get the total effect  $P_{PS\_BAT}$  and  $P_{BAT\_MCU}$  were added together. The total energy consumption was calculated through discrete integration of the total effect. The average power consumption could then be derived by dividing the total energy consumption with the recorded run time.

### 3.3.3 Notations and Formulas

$U_B$  = Battery voltage

$U_{R1}$  = Voltage drop across R<sub>1</sub>

$U_{R2}$  = Voltage drop across R<sub>2</sub>

R<sub>2</sub> = Power resistor in series with battery an MCU-unit (0.02  $\Omega$ )

R<sub>1</sub> = Power resistor in series with power supply and battery (1  $\Omega$ )

$I_{BAT\_MCU}$  = Current between battery and MCU-unit

$I_{PS\_BAT}$  = Current between power supply and battery

$I_B$  = Current to and from battery connected to the MCU

$I_{PS}$  = Current to battery from power supply

$P_{BAT\_MCU}$  = Power exchange between battery and MCU-unit

$P_{PS\_BAT}$  = Power from power supply to battery

$t_1$  = Time at start

$t_2$  = Time when finished

Current through voltage drop across power resistor  $R_2$ :

$$I_{BAT\_MCU} = \frac{U_{R2}}{R_2} = \frac{U_{R2}}{0.02} = 50U_{R2} \quad (1)$$

Current through voltage drop across power resistor  $R_1$ :

$$I_{PS\_BAT} = \frac{U_{R1}}{R_1} = \frac{U_{R1}}{1} = U_{R1} \quad (2)$$

Power to and from MCU:

$$P_{BAT\_MCU} = U_B * I_{BAT\_MCU} \quad (3)$$

Power from Power supply:

$$P_{PS\_BAT} = U_B * I_{PS\_BAT} \quad (4)$$

Total power:

$$P_{tot} = \int_{t_1}^{t_2} (P_{BAT\_MCU} + P_{PS\_BAT}) dt \quad (5)$$

Average power:

$$P_{avg} = \frac{P_{tot}}{t_2 - t_1} \left( \frac{J}{s} \right) \quad (6)$$

### 3.4 Testing

The testing phase started with several weeks of trial and error to learn proper test procedures and eliminate test errors. A short phase of trials was run for two weeks where test procedures were fine-tuned before starting the proper test sequence.

#### 3.4.1 Reference testing

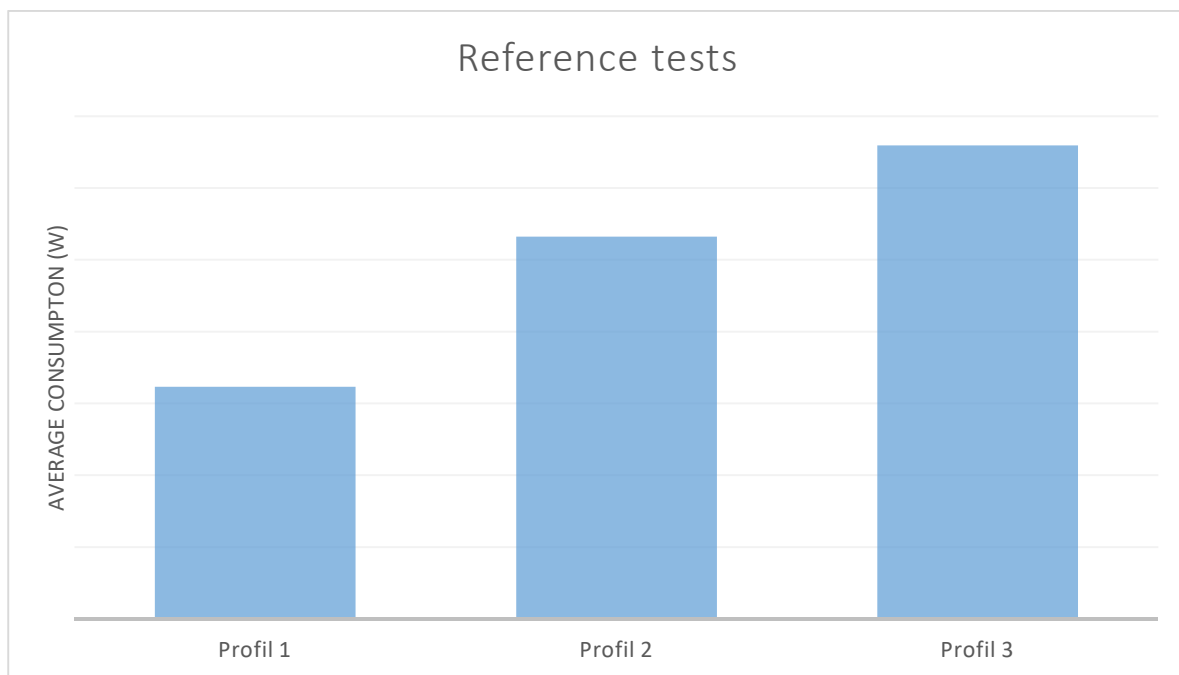

[Figure 3-6] Reference test with sensors connected and plastic wheels

Reference tests were run on all profiles before any optimisation attempts were made. Figure [3-6] shows the relative energy consumption between the different profiles.

The door software settings were tested to find the best matches for the reference profile opening times, closing times, and hold-open times. These settings are recorded as setting A, B, and C respectively in the appendix. Because the SL-500 on the test rig did not allow for settings that would exactly match the desired profile values they were selected to provide as close a match as possible. The deviations never exceeded half a second in the timing settings and no more than 5 cm/s in the speed settings.

Three initial reference tests were made for each profile. One with the door sensors connected, one without, and for the final reference test the profiles were tested with steel wheels instead of plastic wheels and the sensors connected.

### 3.4.2 Regeneration testing

One possible way to reduce energy expenditure and increase energy efficiency would be to recover the energy created when the DC motor is braking as this generates a current which is fed back into the system. [9] The MCU is designed with a number of safeguards to prevent excess current from feeding back into the power grid or into the batteries so in order to test regeneration these safeguards need to be circumvented.

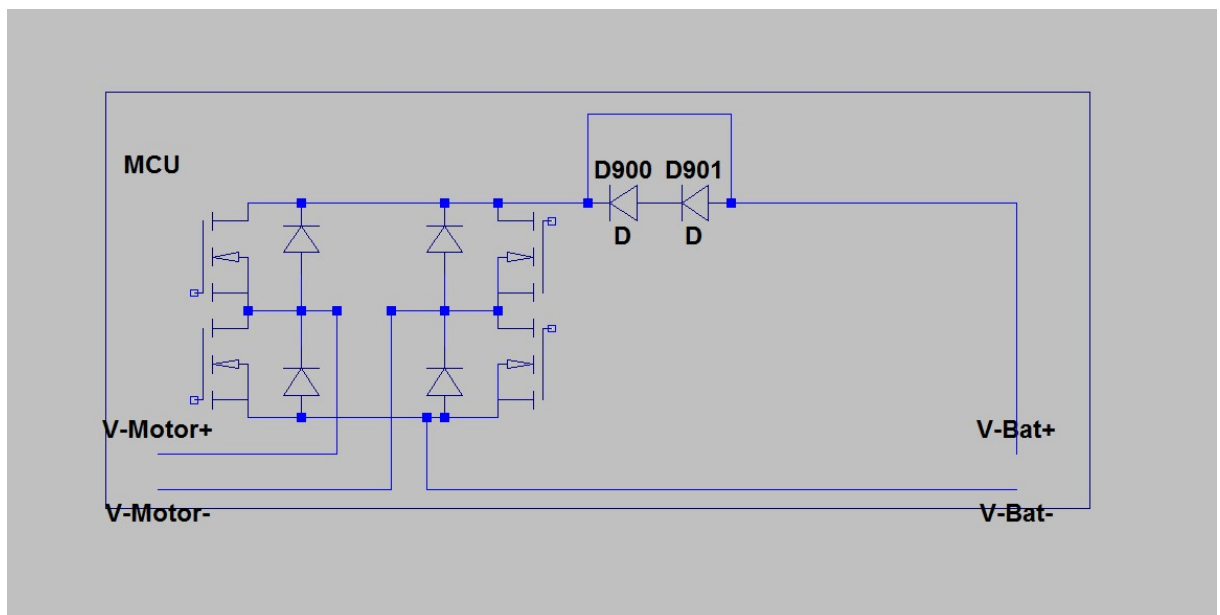

[Figure 3-7] Simplified regeneration schematic

Figure [3-7] shows a simplified schematic of the motor connected to a 4-quadrant DC converter [5] in series with two diodes. When the door is braking the converter operates in the fourth quadrant and regenerates current. The two diodes, D900 and D901, was a first safeguard that was preventing current from flowing back into the battery packs. Since the energy cannot be fed back into the power grid

the only feasible way to recover the energy is to store it in the battery packs. In order to get current into the batteries these diodes would have to be short circuited. The current could then be fed into the battery circuit. Battery current was already being measured by the DAU and the input resistance of the PS was high enough to prevent leak currents so once the diodes were short circuited the brake-induced current should go into the battery packs. One possible danger here was that the current would produce a voltage spike that would harm the batteries but a resistor grid on the MCB makes sure that the system voltage never exceeds 38 V. Overvoltages would trigger this safeguard which switches the circuit over to the resistor grid that would burn up the extra voltage as heat. This would also protect the battery packs during regeneration. Since 38V is only nine volts over the normal output voltage of the batteries at full charge it would not cause a voltage spike hazard.

In any event the results showed that voltage spikes were never an issue. Repeated testing showed that if there was any regenerated current from the MCU then it was barely measurable. Since this was not the result expected from the tests this forced a rethinking of the tests to see if there were any possible errors in the test methods or if there were any additional safeguards or constraints on the MCU that acted to prevent regenerated current from flowing to the batteries.

No errors were found and the MCU did not seem to be the problem either so that led to the conclusion that the system voltage was simply lower than the battery voltage and the voltage spikes during braking were not long enough or high enough to induce a current from the MCU into the battery.

This hypothesis needed to be tested and the method settled on was a tweak in the MCU software to change the operating parameters of the door. The idea was to make the door brake harder and make the door brake for a longer period of time. That should be enough to increase the system voltage above the battery voltage and show up on the measurements. If it did not then the problem had to be found somewhere else.

To make this happen a variable change was introduced to the door weight calculations in the door's programmable software which is run on the MCU. The door software will measure the weight of the door leafs during a Learn cycle which is always run when a door is first

installed, and which was also run every time a test profile was changed in the lab. The variable change increased the measured weight by a factor of 2. Since the MCU perceives the door to be heavier it makes the motor run harder to open it, boosting the opening speed above normal. The door, moving faster than usual, triggers the brake function in the software when it comes near the end of its movement but since it has increased momentum the MCU applies progressively more force to break it.

Tests on the reprogrammed MCU showed clear evidence of current regeneration but as the motor was forced to run faster it also consumed a lot more energy, far more than what was being regenerated. The hypothesis was confirmed but current regeneration did not seem to be a feasible way forward for energy optimization.

### 3.4.3 Optimization testing

A series of tests were run to determine the lowest possible power consumption for each profile.

Power regeneration did not produce the desired returns and it was not applied for these tests. The low-power tests were run on profile 1 on MCB setting D, with steel wheels and no sensors connected,

With optimization allowing at least one profile to run below 15W of energy consumption this opened up an avenue for exploring alternate power sources where the big power source could be replaced with off-the-shelf components.

A first attempt was made to allow the door to be powered from a USB connection. This involved a regular USB connector wall plug made for powering phones or tablets and a modified USB-cable. The wall plug was rated at 2.4A at 5V. This would give 12W which was low but could be sufficient if the optimisations were in effect.

The USB cable was cut close to the connector head and thicker copper wire was soldered on to minimise resistance as the regular USB power cables were deemed too thin to handle the required current without significant energy losses. The modified cable was connected to a DC-DC converter [4] to boost the voltage up to 29V so it could supply the battery packs. This approach quickly failed during testing as the wall plug refused to deliver the rated effect. Instead of the 12W it was rated

at the tests showed it only delivered 5-6W when pushed hard. The oscilloscope was used to try to determine the cause for this behaviour and it showed that some form of overcurrent limiter kicked in which reduced the voltage below 3V. The DC-DC converter was rated with a minimum of 3V input requirement so having the input voltage drop below rated voltage caused unpredictable behaviour. In reference tests the door openings would have 5-6A current spike from the batteries while the PS would always deliver its set max current, but there was no way to control the current limiter in the USB wall plug. The wall plug was set to aggressively limit overcurrents and reduced the effective current to a fraction of the rated limit to protect itself.

Testing of the wall plug using the DC-DC converter showed that the current limiter would kick in when the current exceeded 1.7A at 5V. This was far below expectations but could most likely be attributed to poor components used in the USB wall plug. Replacing the plug was considered but most USB plugs on the market would deliver less than 10W. Finding something in the 12-15W range was almost impossible. The tested wall plug was an outlier when it came to the specified effect but it is likely that it was an outlier because it promised more than it could reasonably deliver.

Since a replacement component seemed unlikely to deliver improved performance work continued on the existing wall plug to see if it was possible to work around the current limiter. Adding a second DC-DC converter in series with the first to provide an intermediate step up in voltage was the first attempt. This new DC-DC converter only required a 2V input so it could be relied upon not to suffer any efficiency losses even if the output voltage from the wall plug dropped below 3V as it had been shown to do. An additional converter would mean additional heat losses during power conversion but these would hopefully be offset by getting stable power out of the wall plug. Testing showed this to be partially successful, but only partially. There were modest gains in output but still nowhere near enough to reliably run the door for a full test profile. At best the USB wall plug was able to deliver 6W.

By limiting the current drawn from the USB wall plug it may be possible to get more power from it because it lowers the output voltage when pushed to its limit. Experimentation could find an optimal power output curve. To limit the current drawn from the USB wall plug a solution was devised using a PWM controlled transistor which was connected in series from the output of the DC-DC converter. A spare Arduino board

was used to regulate the transistor like a digital resistor and the Arduino board measured the current through the voltage drop over a 0.02 Ohms power resistor in series with the wall plug and the DC-DC converter. A simple P-regulator, or proportional regulator, was implemented in the Arduino code which controlled the duty cycle for the already existing PWM function. This seemed to work with a power resistor as a dummy load but failed when used to charge the batteries since it shorted the Arduino board due to common ground. Work on this custom solution was eventually put aside since time was not available to develop it further and it was not a central part of the project.

For a simpler solution the USB charger was replaced by a stock 25W AC-DC wall adapter which worked very well, both due to a higher rated load as well as because it was much less aggressive in limiting overcurrents.





## **4 Results and Analysis**

The traffic measurement data and recorded test has not been included in this report in order to safeguard AAES proprietary information. For this reason exact test data will not be published but the analysis of the data is generally applicable and is presented in this chapter.

### **4.1 Results**

The conclusion of seven weeks of testing shows that there are several avenues to explore to reduce energy consumption and improve sustainability on sliding door systems. Energy consumption is the overriding factor here and the most important one when it comes to increasing sustainability.

The energy consumption varied greatly when different traffic profiles were run on the door. Using reference settings and P1 as a baseline P2 consumed 65 % more energy while P3 consumed 104 %. See appendix A for detailed information on the settings used.

### **4.2 Sensors**

The largest measured reduction in power consumption came from physically removing the sensors. The power draw as a percentage of the total power consumption is significant. The improvement is 39% with P1, 22% with P2, and 25% on doors using P3. See figure [4-1]. Unfortunately these figures do not represent attainable savings in power consumption. On a working door the sensors are integral to the system, without them the door will not function. The question is then, what savings can be made?

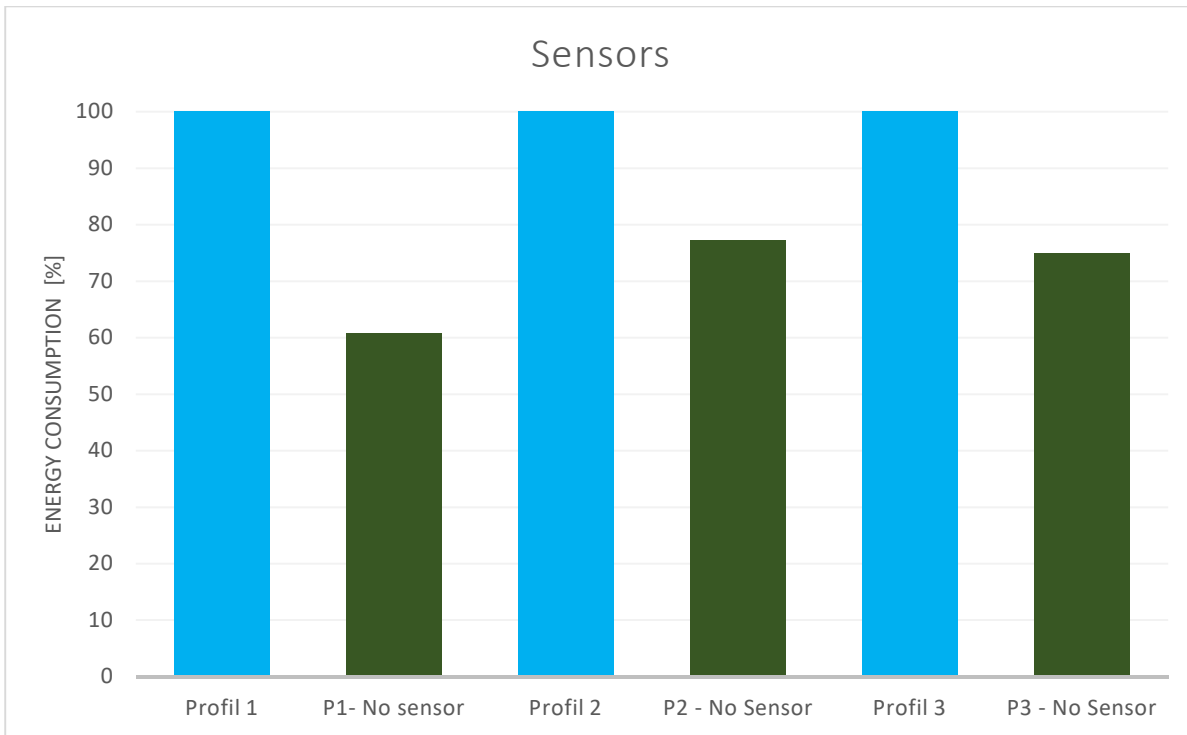

[Figure 4-1] Sensor savings

When considering this problem the immediate conclusion was that some kind of mechanism to power down the sensors when not in use should be looked into. A stand-by mode where the sensors power on intermittently, check to see if there is a presence, and then power down again if no presence is detected would be the ideal scenario.

Unfortunately none of the methods that were researched provided a workable way to achieve this.

Consultation with ASSA Abloy staff revealed that the sensors would not respond well to toggling the sensor power inputs on and off as there is a prolonged start-up sequence before they are operational. That put an immediate end to any idea of forcibly regulating the power by toggling the current to the sensors on and off. Analysis of the MCB software coupled with consulting the engineers responsible for maintaining the software showed no feasible way to reduce sensor power draw through re-programming the MCB.

Sensors are also a safety feature used to prevent people from getting hit by a moving door leaf. It is not clear if the ideas for power reduction would negatively impact user safety.

Sensors are available as separate components and available from a variety of manufacturers and when installing a door system the solution here seems to be to pick the most energy efficient sensor available on the market.

### **4.3 System settings**

The system software settings are accessible through the four-button control panel which provides a quick and easy way to lower energy consumption by reducing door performance. Increased energy efficiency is gained at the cost of door speed. On P1 the change from medium-performance (3) to low-performance (1) resulted in a 6% decrease in energy consumption. On P3 a change from high-performance (5) to low performance (1) also resulted in a 6% decrease. These are modest improvements but improvements that can be made on all doors without modification. The decreased door speed might not be desirable in all use cases but that is left up to the end-user to decide.

### **4.4 Regeneration of energy**

On an unmodified MCB there will never be any regeneration at all to the batteries due to the two blocking diodes d900 and d901, see figure [3-7], though some energy is likely fed back to the control unit and the sensors. The two diodes were shorted to enable energy to be fed from the system back into the batteries.

The motor controller software was modified to increase the acceleration and deceleration speeds. A faster door needed to brake harder and that would in turn generate a higher system voltage which could hopefully induce a current into the batteries. With the modifications in place the battery current graph for the tests showed that a negative current peak could be detected during deceleration which indicated that some amount of energy was being re-fed to the battery. While this test proved that regeneration could take place under the right circumstances the energy cost for having more powerful accelerations and decelerations was a substantial net loss in energy efficiency. The additional energy costs were 18 times greater than the regenerated energy that was fed back to the battery. The modified door

proved that regeneration was theoretically possible but it was not of any practical use.

In graph [4-2] the blue line represents the measured battery current during tests with the modified door software, with positive values showing current from the batteries and negative values showing current charging the batteries. The shaded area above the line shows energy consumption while the shaded area below the line shows regeneration. Some regeneration is taking place but the effects on overall energy consumption are negligible as a comparison of the relative areas will show.

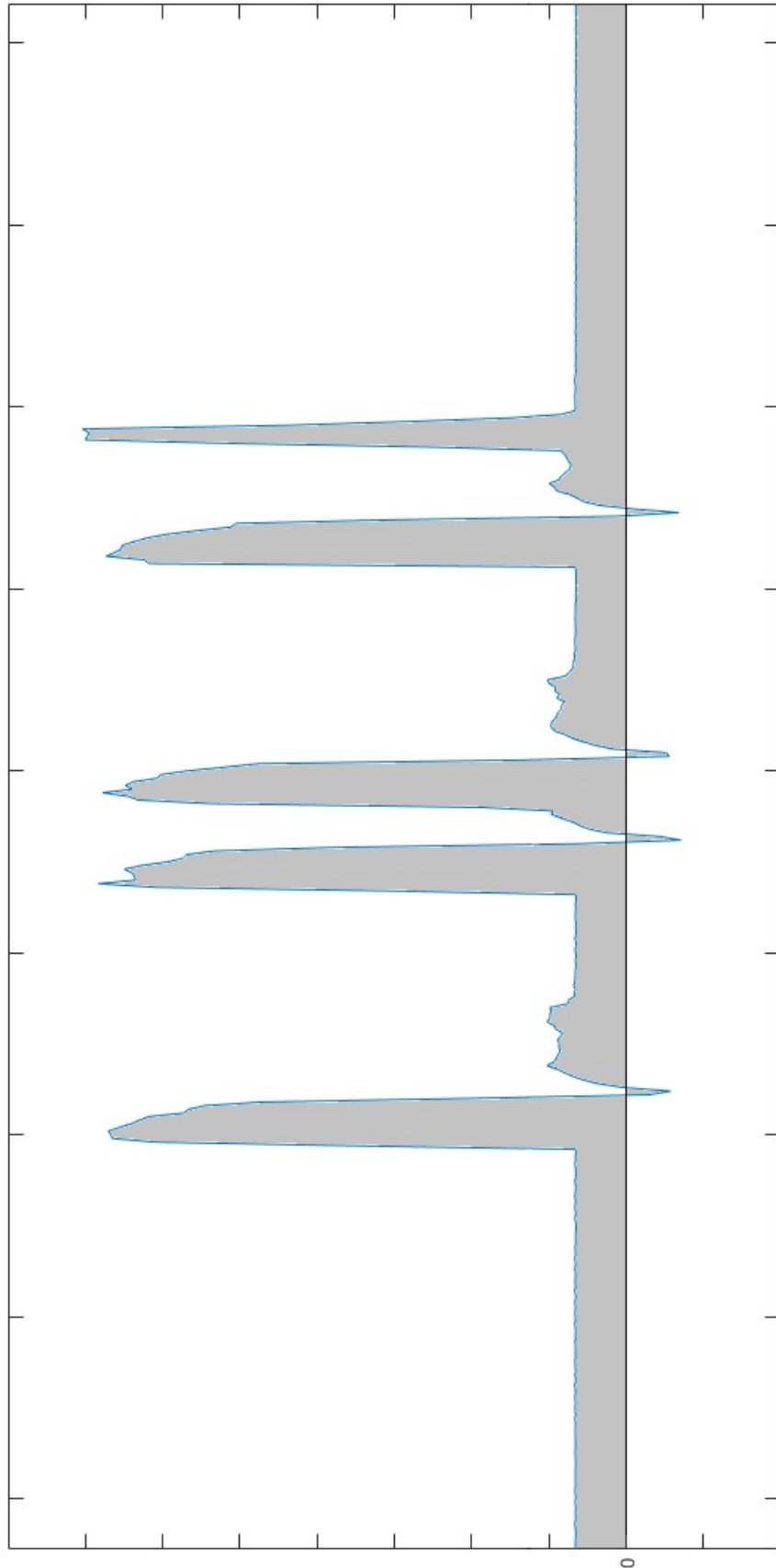

[Figure 4-2] Battery current

## 4.5 Different wheels

The SL-500 sliding door can be installed with one of several different types of wheel. Testing was done on two types, one set of plastic wheels with a rubber rim and one set of steel wheels.

All profiles were run with both sets of wheels with the hypothesis that the steel wheels have a lower friction coefficient. The hypothesis was proven as profile 1 consumed 6.2% less energy equipped with steel wheels than with the rubber coated plastic wheels. Steel wheels were even more effective on the heavier doors in profile 3 where they reduced energy consumption by 15.9% and on the heaviest door, profile 2, the steel wheels reduced energy consumption by 23.7%. Comparative results are shown in figure [4-3].

Heavier door leafs get a progressively larger reduction in energy consumption by using steel wheels as friction becomes a larger factor in the overall energy consumption.

A final note on steel wheels concerns noise levels. According to the AAES staff consulted for the project the reason why rubber-coated wheels are commonly preferred over steel wheels is because they are less noisy. Noise levels were not part of the test parameters but during testing steel wheels were not noticeably louder than rubber-coated wheels.

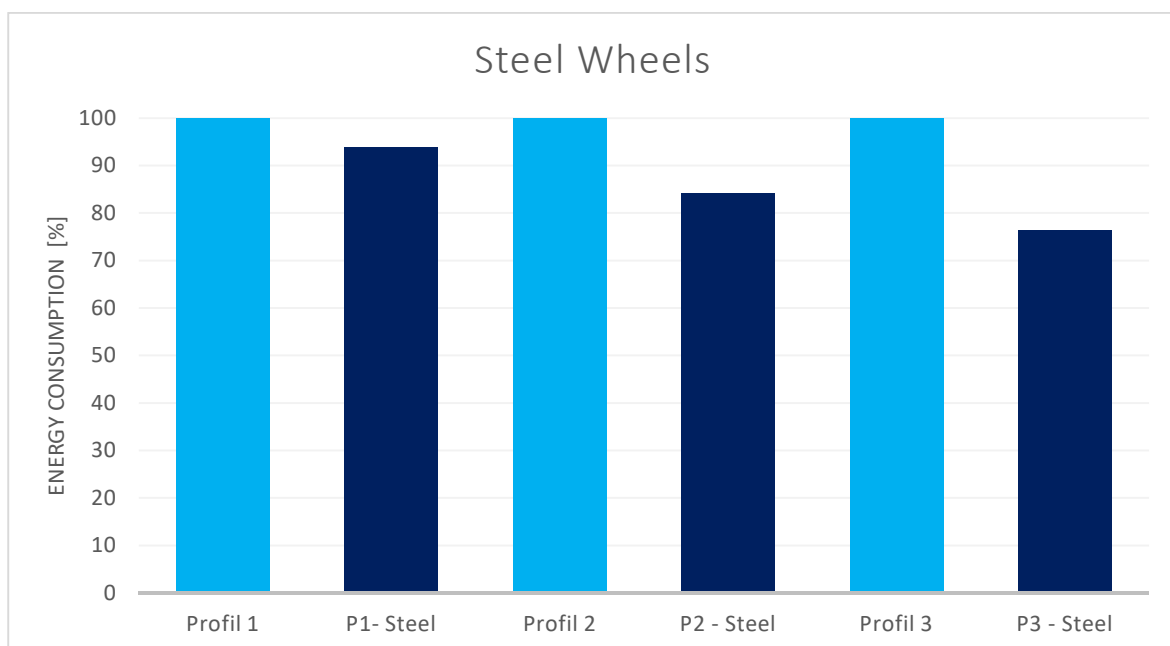

[Figure 4-3] Steel wheel savings

## **4.6 Battery-assisted power supply**

All testing was conducted with the door power supply (PSU) disconnected. At the start of the project this was done to get around the problem of accurately measuring current supplied from the PSU. By setting up a circuit with a separate power supply in parallel with the battery packs this provided an easier way to see exactly how much energy was used by the door and how much was stored in and discharged from the batteries. As testing got under way it became apparent that this setup could be used as an alternate way to power the door. The batteries would handle the peak load currents at door acceleration and deceleration while the connected power source would supplement them and charge up the batteries between openings.

One potential drawback with using the batteries as a primary power source instead of as an emergency backup is that the emergency batteries are used to open the doors in case the main power is lost. This is a useful safety feature and when implementing a battery-driven power source additional measures would need to be taken to make sure that this feature is not lost.





## **5 Conclusions**

After several weeks of collecting data and testing the door the different optimizations were compared and the results were favourable. Energy consumption can be reduced. Test results conclusively prove that several of the tested methods to reduce energy consumption work and some of them provide notable gains.

### **5.1 How was door traffic measured?**

With no prior experience with sliding doors the quickest way to learn how traffic flowed through them was to go out in the field and observe.

Traffic was measured by observation with pencil, paper, stopwatch, and a mechanical counter. Given the limitations imposed by the time and manpower available the observations collected as much data as was possible. The work was not easy as it required focusing on moving crowds over an extended period of time and observation errors inevitably crept into the data. In an attempt to mitigate this several observation sessions were made so that individual errors could be averaged out, and with two people making observations the tallies could be checked against each other at the end of every observation session providing an additional safeguard against errors.

Better results could have been obtained if the doors could have been recorded by video camera for extended observation sessions. This would have made for easier counting as well as being a physical record to refer back to. Getting permission to record people while on private property would significantly complicate the time frame of the study however. Sitting with a pen and a notepad is much less intrusive and when permission to sit down and write was needed it was easy to get cooperation from the property owners.

The observations captured the number of passages, openings, re-openings, group sizes, and time open, as well as separately measuring door size and speed. These data points were enough to create a satisfactory model of traffic but while working on the model it would have been beneficial to get more data for a more accurate model.

## 5.2 How can door traffic be modelled?

The first problem encountered was making a model that was representative of the collected data. Grouping the data into three different profiles according to traffic patterns meant that fewer tests would be required which would reduce the time constraints on the project, but using profiles made it necessary to find a representative test cycle that could be used. The model needed to produce behaviour similar to a real door. Taking the average of openings and re-openings in a profile and then determining that since there was X amount of openings in an observation session the door should have Y amount of openings/minute would not do. No door has uniformly regular openings and re-openings in the real world. Randomizing the timing sequence of openings and re-openings in some way was needed but the randomization also needed to imitate the pattern of the observed doors.

Originally the plan was to model individual passages but that plan had to be discarded as the gathered data did not allow for that level of granularity. After scaling down the ambition a bit the data did however allow for the modelling of groups which was sufficient for a detailed model that would provide appropriate timing sequences.

The major benefit of the probabilistic model that ended up being used was that it made the merger of data from different doors into a single profile easy. All that needed to be done was to tally the number of size-1 groups, size-2 groups, and so on regardless of the observation session or door, and then calculate a frequency table of observed group sizes from that. The frequency table would be the basis for the profile which could then be programmed into the software model.

The model had a few flaws, mainly related to the time the door was held open. Every opening took a certain amount of time and while this was a function of the number of passages it was not a linear function. Since there was no data for anything but the average time the door was open a separate table was created to modify the increased passage time by group size. Small groups got a minor increase to the total passage time while large groups got a decrease. This can likely be modelled with a mathematical function given more time and test data.

### **5.3 How can the door be optimized for lower energy consumption?**

The change that did the most to reduce energy consumption was the change from plastic wheels to steel wheels. All doors benefit from steel wheels and the more traffic they see the bigger the benefit. If sustainability is the goal then steel wheels should always be used.

The door sensors consume a large portion of the total energy consumption of the door. As the sensors are not a fixed part of the door but a separate module it stands to reason that more energy-efficient modules should be selected in order to promote sustainability.

Power regeneration to the battery was thoroughly tested but is not a workable method to reduce consumption. The measured gains were so small that they fall in the range of measurement error and even on the heaviest door profile the voltage generated by the door braking was barely enough to overcome the battery voltage.

Attempts to use alternate low-energy power supplies to take advantage of the battery-assist through the battery connection instead of using the regular 230V power supply were made but with mixed results. Using a 5V USB-adapter to power the door through the battery connection was probably too optimistic as the door realistically needs at least 10W to run with sensors disconnected and the cheap adapter used did not even live up to the specified power rating. When the current surges as the motor accelerates the adapter went into surge-protection mode and lowered both output voltage and output current. This was true even on the least power-consuming door setup possible. Attempts to use a simple 25W power adapter were immediately successful, showing that component quality matters when trying to chase efficiency.



## 6 Future Development

The sensors consume a lot of energy regardless of use. The specifications of sensor design were outside the scope of this project but since they are a modular extension to the door it should be relatively easy to select sensors optimised for low power consumption and ideally a demand for energy-efficient sensors would make sensor companies try to meet that demand by developing better products.

One interesting avenue for future development is the use of solar panels to supply power. In theory solar panels would be able to replace the lab power supply used during tests and deliver current to the battery packs. Solar power is weather-reliant but batteries can overcome temporary shortfalls in energy while solar panels can charge the batteries when the sun is shining. The potential here is limited by the fact that solar power is highly location dependant. Both geographically as well as physically. A solar panel installed on the Mediterranean coast will see more sunlight than one installed in Lund. A physical installation on the north side of a building will see less sunlight than one at the south side of the same building. Finding good spots to install panels can be difficult. Pursuing this would also require research into what kind of batteries to install as the emergency battery packs are not designed for continuous use. The emergency packs functioned well during testing but the tests were not concerned about battery life or potential battery degradation. In practice solar panel batteries need to be able to handle continues charge and discharge cycles during extended time frames and the NiMh battery packs are not designed to handle that.

An idle door will still consume significant amounts of energy as the door is still required to be able to open at a moment's notice so all systems are active. Most doors are only used actively during a part of the day, usually business hours. Outside of the active hours these doors never open and to be maximally energy efficient they should not stand idle as if they were waiting for traffic but instead shut down, ideally the door should also indicate this unpowered status so that users don't attempt to walk into the door. Having a shut-down mode where most systems are turned off could significantly reduce overall

power draw during hours when the door sees no traffic or very little traffic.

## 7 References

[1] Eriksson, K & Gavel, H, *Diskret matematik och diskreta modeller*. Lund: Studentlitteratur, 2013.

[2] *MATLAB Documentation* (2016) [Online] Available: <https://se.mathworks.com/help/matlab/>

[3] *Installation and Service Manual Sliding Door Operator Besam SL500SL* . AAES, 2015

[4] Mats Alaküla and Per Karlsson, *Power Electronics, Devices, Converters, Control and Applications*. Lund University, 2015 v.1, ch. 1.7, pp. 26-28

[5] Mats Alaküla and Per Karlsson, *Power Electronics, Devices, Converters, Control and Applications*. Lund University, 2015 v.1, ch. 2.5, pp. 59-65

[6] Alexandra von Meier, *Electric Power Systems*. Hoboken, NJ, USA: John Wiley & Sons, Inc., 2006, ch. 4

[7] *Arduino UNO technical specs* (2016) [Online] Available: <https://www.arduino.cc/en/Main/ArduinoBoardUno>

[8] *Arduino programming language reference* (2016) [Online] Available: <https://www.arduino.cc/en/Reference/HomePage>

[9] *Four Quadrant Operations of DC Motor* (2016) [Online] Available: <http://www.electronicshub.org/four-quadrant-operations-of-dc-motor/>





## Appendix A

Settings 2, 3, and 15 were the only variables changed between the different profiles.

Setting #	Profile <u>A</u>	<u>B</u>	<u>C</u>	<u>D</u>	<u>E</u>	<u>F</u>	<u>G</u>
<b>2</b>	70	70	25	70	70	25	70
<b>3</b>	3	1	2	3	1	2	3
<b>15</b>	3	5	5	1	1	1	5